

Geotechnical Recommendations Report

MSU Grant Chamberlain and Paisley Court Parking Lot Reconstruction

Bozeman, Montana

Tetra Tech Project No. 117-8598103
May 1, 2023

PRESENTED TO

Montana State University Facilities
Attn: Mr. John Scott
PO Box 172760
Bozeman, MT 59717

PRESENTED BY

Tetra Tech
7100 Commercial
Ave, Suite 4
Billings, MT 59101

P +1-406-543-3045
www.tetrattech.com

Prepared by:



Treven Hembree
Geotechnical Engineer



Marco Fellin, P.E.
Senior Geotechnical Engineer



5/1/2023

TABLE OF CONTENTS

1.0 PURPOSE AND SCOPE OF STUDY	2
2.0 PROJECT UNDERSTANDING	2
3.0 EXISTING CONDITIONS.....	2
3.1 Grant Chamberlain	2
3.2 Paisley Court	2
4.0 FIELD EXPLORATION.....	2
5.0 LABORATORY TESTING	3
6.0 SUBSURFACE CONDITIONS	4
6.1 Asphaltic Concete.....	4
6.2 Base Course.....	4
6.3 Separation Fabric	4
6.4 Clay.....	4
6.5 Native Gravel.....	5
7.0 PAVEMENT SECTION DESIGN AND CONSTRUCTION	5
7.1 Alternative 1 – Imported Gravel Fill.....	6
7.2 Alternative 2 – Reclaimed Asphalt & Base Course Fill	6
7.3 Pavement Reclamation and Construction	6
8.0 CONTINUING SERVICES	7
9.0 LIMITATIONS	7
DRAWING 8103: LOCATIONS OF EXPLORATORY BORINGS.....	8
APPENDIX A: LOGS OF EXPLORATORY BORINGS	9
APPENDIX B: LABORATORY TESTING.....	10
APPENDIX C: PHOTOGRAPHS.....	11
APPENDIX D: RECLAMATION SPECIAL PROVISIONS	12
APPENDIX E: IMPORTANT INFORMATION	13

1.0 PURPOSE AND SCOPE OF STUDY

Tetra Tech is pleased to present this Geotechnical Recommendations report for the design and reconstruction of the Grant Chamberlain and Paisley Court parking areas. This report presents the results of our March 29th field exploration and the subsequent laboratory testing and analyses. Following is a summary of the geotechnical exploration including boring logs, a description of subsurface conditions, pavement section thickness, and construction requirements.

2.0 PROJECT UNDERSTANDING

We understand Montana State University (MSU) proposes to reconstruct the parking and drive lanes associated with the Grant Chamberlain and Paisley Court student housing units. The existing asphalt pavement is approaching the end of its service life and contains numerous potholes, rutting, and fatigue cracking. MSU proposes to reconstruct the parking lots either by a standard mill and replacement or an overlay to improve the drivability and reduce associated maintenance costs.

3.0 EXISTING CONDITIONS

Current parking areas generally consist of a center drive lane with parking on both sides. The parking lots serve multiple-story apartment buildings for MSU campus residents.

3.1 GRANT CHAMBERLAIN

The Grant Chamberlain parking area services six three-story apartment buildings orientated in a horseshoe shape with two access drives, one from College Street and one from 15th Street. Both sides of the parking lot contain concrete parking stops at the designated parking locations. The south side of the parking area (towards the apartment buildings) has a four feet wide asphalt sidewalk for tenant access. Additionally, three-foot-high car plug in posts are located in the sidewalk areas. There is approximately one post for every two parking spots along the south parking row. Multiple concrete pads for dumpster storage locations were observed within the parking area.

3.2 PAISLEY COURT

Paisley Court consists of two separate parking lots within the Paisley Court apartment building complex. Both parking areas were constructed in the same configuration consisting of a single access drive to Garfield Street, a rectangular shape with center and outside parking, a center island containing light posts and an electric plug-in rail, and the parking areas contain exterior curb and cutter concrete pavements. The parking areas serve multiple two-story apartment condos.

4.0 FIELD EXPLORATION

We performed a geotechnical subsurface exploration within the Grant Chamberlain and Paisley Court Parking areas on March 29th, 2023. Prior to the subsurface exploration, we marked exploratory locations and Montana One Call (811DIG) was contacted to request the location and clearance of public underground utilities before performing drilling. MSU facilities personnel visited the site to identify any conflicts with public utilities.

We subcontracted O’Keefe Drilling from Butte, Montana to provide a drill rig and crew to advance the exploratory borings within the parking areas. O’Keefe advanced four borings within the Grant Chamberlain parking area, and two borings in each parking area in the Paisley Court complex. Borings were advanced using a truck-mounted Mobile B60X drill rig equipped with 8-inch outside diameter, continuous flight, hollow stem augers. As the boring progressed, Tetra Tech’s onsite field engineer provided technical oversight, which consisted of observing drilling operations, visually classifying soil samples collected, bagging select soil samples for laboratory testing, and developing field borehole logs.

Samples of the subsurface materials were collected by advancing 2-inch outside diameter split-spoon samplers into the subsurface strata using a 140-pound hammer falling 30 inches onto the drill rods. The number of blows required to advance the sampler each of three successive 6-inch increments was recorded and the total number of blows required to advance the sampler the second and third 6-inch increments is the penetration resistance (N value), as described by ASTM International (ASTM) Method D1586. Penetration resistance values generally indicate the relative density or consistency of the subsurface soils. Bulk samples of disturbed materials were collected from auger cuttings for moisture density testing.

Boring logs were prepared noting the borehole location and elevation, equipment and drill methods used, subsurface profile and descriptions per ASTM D2487, and groundwater conditions (not encountered). Depths at which the samples were obtained along with the penetration resistance values are shown on the logs of exploratory borings, presented in the Log of Boring attachments (Figures A1 through A8 in Appendix A). Boring locations are shown on Drawing No. 8103-1.

5.0 LABORATORY TESTING

Samples obtained during the field exploration were taken to Tetra Tech’s laboratory where they were observed and visually classified in accordance with ASTM Method D2487, which is based on the Unified Soil Classification System. Representative samples were selected for further laboratory testing in our Billings soil laboratory. Soil samples were tested to determine the physical properties of the soils in general accordance with ASTM or other approved procedures. The following list describes laboratory testing performed and their purpose:

Tests Conducted:	To Determine:
Grain-size Distribution	Size and distribution of soil particles (i.e., clay, silt, sand, and gravel).
Atterberg Limits	The effect of varying water content on the consistency of fine-grained soils.
Moisture Content	The percent moisture contained in soil samples.
Moisture-Density Relationship	The optimum moisture content for compacting soil and the maximum dry unit weight (density) for a given compactive effort.

Field and laboratory test results presented in Figures B1 through B6 in Appendix B. Sample photographs are presented in Appendix C. This data, along with the information collected during our field exploration, was used to prepare the exploratory boring logs presented in Appendix A.

6.0 SUBSURFACE CONDITIONS

The subsurface soil profile generally consisted of a three-inch asphalt concrete surfacing, underlain by approximately 6 to 12 inches of gravel base course material. Underlying the base course material was natural clay subgrade that extended to about three to five feet below the ground surface (bgs) and was underlain by native gravels. Groundwater was not encountered at the time of the exploration. The boring logs should be referenced for complete descriptions of the soil types and their estimated depths.

6.1 ASPHALTIC CONCETE

Asphaltic concrete was encountered at the surface of all the borings and ranged from approximately 1- to 4-inches thick and was typically about 3-inches thick on average. The asphalt was generally in poor to fair condition.

6.2 BASE COURSE

The layer immediately beneath the asphalt consisted of a granular base course that was approximately 6- to 12-inches thick within the Grant Chamberlain Parking area and was approximately 6- to 10-inches thick within the Paisley Court Parking areas. This layer appeared to be an unprocessed pit run gravel material containing a few 3-inch plus gravels. Gravels were subrounded to rounded and had a low percentage of fractured faces. A combined sample of the base course was tested for both the Grant Chamberlain and Paisley Court parking areas. Results of the testing indicate the Grant Chamberlain base course classified as a clayey gravel with sand (GC) and contained approximately 13 percent fines; results of the testing are shown in Figure B1. Paisley Court laboratory testing indicated the base course classified as a silty, clayey gravel with sand (GC-GM) and contained approximately 14 percent fines; results of the testing are shown in Figure B3.

6.3 SEPARATION FABRIC

A geotextile separation fabric was visually observed in Borings 23-05 and Borings 23-08 within the Paisley Court Parking Areas. The separation fabric was observed in the borehole annulus separating the native clay subgrade and gravel base course. We did not observe a separation fabric in the recovered split spoon samples or in the boreholes within the Grant Chamberlain Lot.

6.4 CLAY

The layer immediately beneath the granular base course consisted of a natural clay soil that extended to about 3 to 5 feet bgs in the Grant Chamberlain Lot and extended to about 3.5 to 5.5 feet bgs in the Paisley Court Lot. At the time of our exploration the clay soils were seasonally frozen and contained excess pore water and visible ice crystals, indicating excess free water during the freezing process. A combined sample of the native clay was tested for both the Grant Chamberlain and Paisley Court parking areas. Results of the testing indicated the clay classified as a gravelly lean clay (CL) in both parking areas. Liquid limits for both tests ranged from 31 to 25 percent and plastic limits ranged from 18 to 17 percent. Results of the testing are shown in Figures B2 and B4. Moisture density tests from combined clay samples collected from both parking areas indicate theoretical maximum dry densities of 111 to 109 pounds per cubic foot with optimum moisture contents of 14 and 15 percent, respectively. Moisture density test results are shown in Figures B5 and B6.

6.5 NATIVE GRAVEL

Underlying the clay soils, we encountered native alluvial gravels that extended past the depth of exploration in each borehole. Native gravels were generally coarse subrounded to rounded alluvial gravels. SPT blow counts within the gravel soils ranged from 34 to over 50 blows per foot indicating a dense to very dense relative consistency.

7.0 PAVEMENT SECTION DESIGN AND CONSTRUCTION

A pavement section is a layered system designed to distribute concentrated traffic loads to the subgrade. Performance of the pavement structure is directly related to the physical properties of the subgrade soils and the traffic loadings. A uniformly compacted subgrade is vital for good pavement performance. Traffic within the Grant Chamberlain and Paisley Court parking areas is expected to be light to moderate, consisting of passenger cars, pickup trucks, garbage trucks, and occasional fire trucks. Tetra Tech estimated a maximum of 10 ESAL's per day over the next 20 years.

Pavement design procedures are based on strength properties of the subgrade and pavement materials, along with the design traffic conditions. For pavement thickness design, soils are represented by means of a California Bearing Ratio (CBR) value. The existing subgrade consisted of clay soils that are considered poor subgrade materials based on the AASHTO Soil Classification Chart. A representative CBR value of 3 was used for the native clay subsoils. For imported gravel fill and onsite reclaimed asphalt and gravel fill, a representative CBR value of 40 was used in the parking area design.

Based on the anticipated traffic loading and the subgrade soils encountered during our exploration we recommend reconstructing the Grant Chamberlain and Paisley Court Parking Areas by:

- removing the existing asphalt and base course sections,
- re-grading the natural clay subgrade to the desired elevation and slope (if necessary),
- proof rolling the subgrade with a fully-loaded dump truck to identify soft areas, and replacing any soft or pumping soils with a high-strength geotextile fabric (Mirafi-380i or equivalent) and a minimum of 2 feet of pit run gravel fill.
- placing a woven geotextile separation fabric over the remainder of subgrade (Mirafi 180N) or equivalent).
- constructing one of the two pavement section Alternatives discussed below.

7.1 ALTERNATIVE 1 – IMPORTED GRAVEL FILL

One option for the Grant Area and Paisley Court Parking Area reconstruction is to replace the existing pavement section with 12-inches of crushed gravel fill material and a 3-inch asphaltic concrete surfacing coat. A woven geotextile separation fabric (Mirafi 180N or equivalent) should be placed below the base course material to prevent fines migration into the base course.

7.2 ALTERNATIVE 2 – RECLAIMED ASPHALT & BASE COURSE FILL

The second option to reconstruct the Grant Area and Paisley Court Parking Area is to replace the existing pavement section with 10-inches of reclaimed asphalt/base course material and cap with 4-inches of imported gravel fill, and surface with an approximately 3-inch asphaltic concrete surfacing coat. A woven geotextile separation fabric should be placed below the reclaimed asphalt base course material to prevent fines migration into the base course. The table below shows the minimum pavement design section and applicable compaction criteria.

Material	New Section Thickness (inches)	Reclaimed Section Thickness (inches)	Minimum Compaction ASTM D698 (%)
Asphalt Concrete Surfacing (MDT Grade B or equivalent)	3	3	NA
Crushed Granular Fill (MDT Grade 6A or equivalent)	12	4	95
Subbase: Reclaimed Asphalt/Base	NA	10	95
Separation Fabric	Mirafi 180N or equivalent	Mirafi 180N or equivalent	NA
Subgrade	NA		95
Total	15	17	

7.3 PAVEMENT RECLAMATION AND CONSTRUCTION

Design and construction criteria presented below should be observed for the pavement section; construction details should be considered when preparing project documents.

1. The existing asphalt pavement and granular base should be removed (Alternative 1) or reclaimed (Alternative 2) the full depth of the existing pavement section. Exploratory borings indicate the existing pavement section is approximately 6- to 12-inches thick and is underlain by a separation fabric in the Paisley Court Parking Areas. If reclaimed asphalt and base course is intended to be reused in the pavement section, the material should be stockpiled onsite for use as subbase material.
2. Following compaction of the subgrade, the layer should be proof-rolled with a fully loaded 10 cubic yard dump truck to identify soft or pumping areas. All soft areas should be sub-excavated and replaced with a Mirafi 380i high strength geotextile and a minimum of 2 feet of engineered gravel fill, and compacted per Item 3. We recommend that Tetra Tech observe the proof rolling operations to make the determination of areas that need to be subexcavated,

- 3. Imported granular fill and reclaimed basecourse/asphalt material should meet the following gradation for use within the parking area pavement section.

Sieve or Screen Size (US No.)	Percent Passing
6-inch	100
3-Inch	90 - 100
No. 4	25 – 50
No. 200	0 – 15

- 4. The base course and subbase material should be prepared by moisture-conditioning to within 2 percent of optimum moisture content and compacting to 95 percent of the dry density as determined by ASTM D698. The testing firm should consider the asphalt millings in the reclaimed layer when evaluating the percent compaction. Once the layer is reclaimed, the testing firm should immediately obtain a sample to determine the maximum dry density and optimum moisture content.

8.0 CONTINUING SERVICES

Two additional elements of geotechnical engineering service are important to the successful completion of this project.

- 1. **Consultation with Tetra Tech during the design phase.** This is essential to ensure that the intent of our recommendations is incorporated in design decisions related to the project and that changes in the design concept consider geotechnical aspects.
- 2. **Observation and monitoring during construction.** Tetra Tech should be retained to observe the earthwork phases of the project, including the site grading and excavations, to determine that the subsurface conditions are compatible with those described in our analysis. In addition, if environmental contaminants or other concerns are discovered in the subsurface, our personnel are available for consultation.

9.0 LIMITATIONS

This study has been conducted in accordance with generally accepted geotechnical engineering practices in the region where the work was conducted. The conclusions and recommendations submitted in this report are based upon the design data submitted to Tetra Tech, data obtained from the exploratory borings drilled at the location indicated, and the proposed construction discussed in this report. The nature and extent of subsurface variations across the site may not become evident until construction. During construction, soil, or water conditions appear to be different from those described herein, this office should be advised immediately so that we can re-evaluate our recommendations.

This report has been prepared exclusively for our client. This report and the data included herein shall not be used by any third party without the express written consent of both the client and Tetra Tech. Tetra Tech is not responsible for technical interpretations by others. As the project evolves, Tetra Tech should provide continued consultation and field services during construction to review and monitor the implementation of our recommendations and verify that our recommendations have been appropriately interpreted. Significant design changes may require additional analysis or modifications of the recommendations presented herein. On-site observation of excavations and foundation bearing strata and testing of fill should be performed by a representative of the geotechnical engineer.

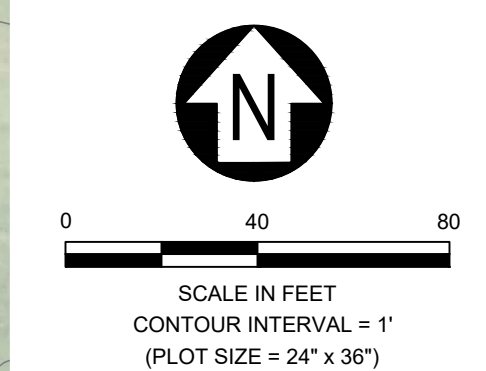

REVISION	DATE	DESCRIPTION

DESIGNER _____ PROJ. NO. 22287
 DRAWN JohnH DATE 1/04/23
 CHECKED _____ SURVEYED DJ&A P.C.

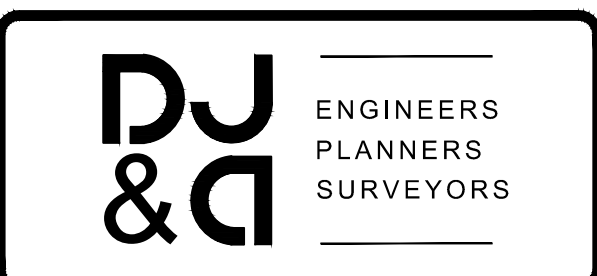

MSU Street & Parking Services

PAISLEY COURT PARKING LOT
Locations Of Exploratory Borings

SHEET
OF
1 1

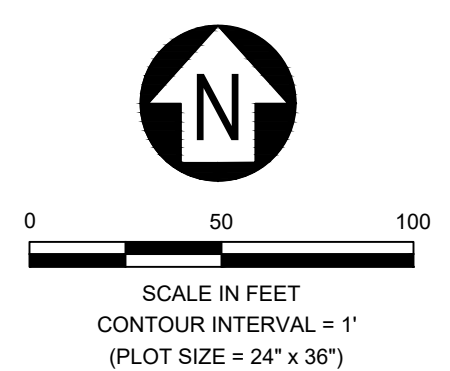
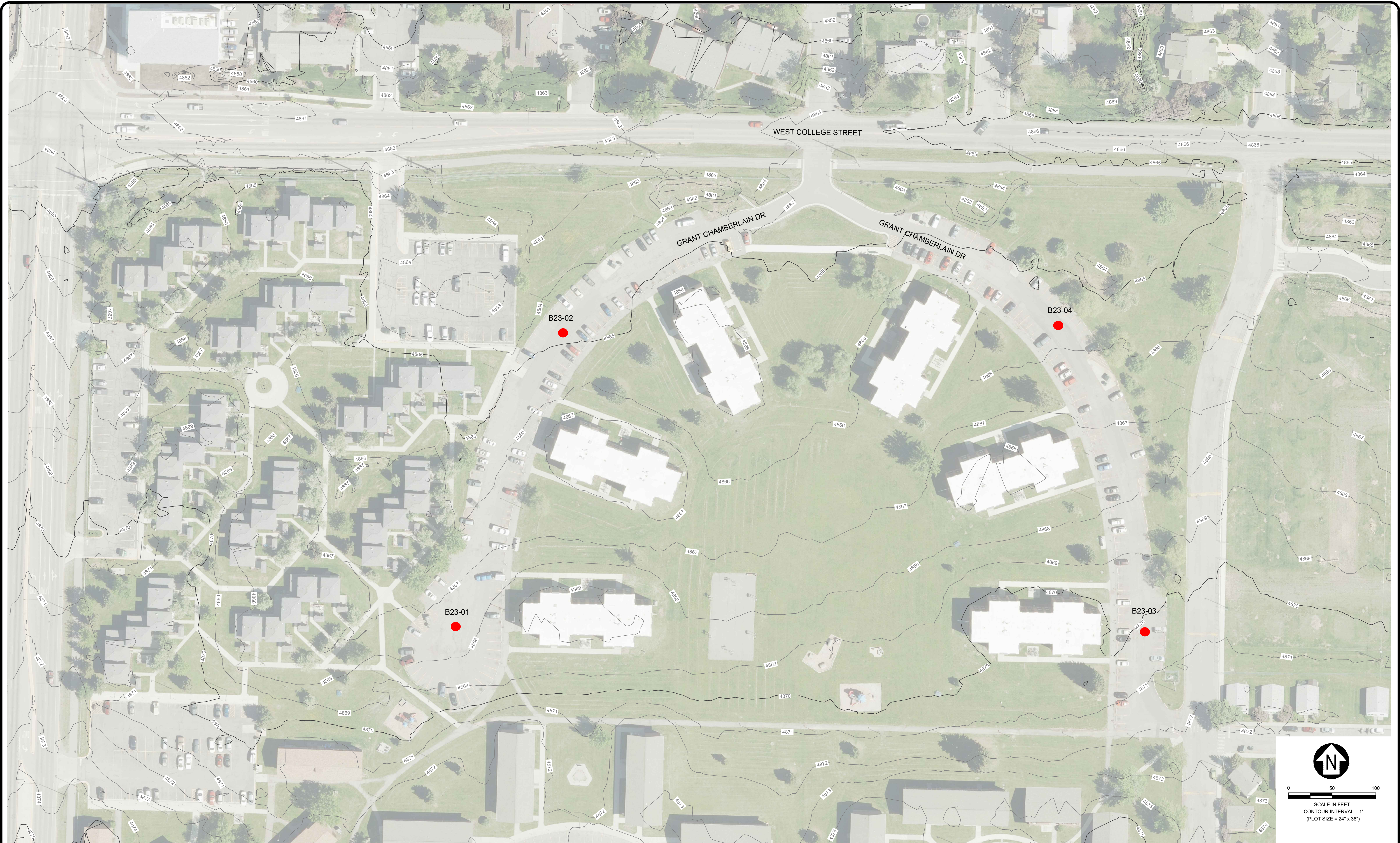

REVISION	DATE	DESCRIPTION

DESIGNER _____ PROJ. NO. 22287
 DRAWN JohnH DATE 1/04/23
 CHECKED _____ SURVEYED DJ&A, P.C.

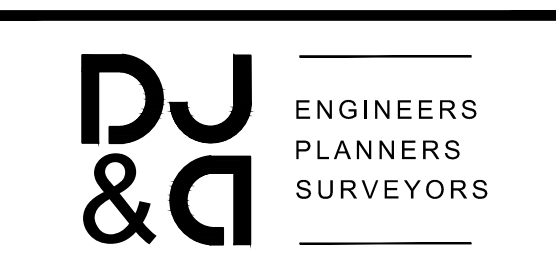

MSU Street & Parking Services

GRANT CHAMBERLAIN DRIVE
Locations Of Exploratory Borings

SHEET
 OF
 1 1

APPENDIX A: LOGS OF EXPLORATORY BORINGS

Boring Logs 23-01 through 23-08

Tetra Tech Boring Log Descriptive Terminology

Key to Soil Symbols and Terms

12/06/12



SOIL CLASSIFICATION CHART

MAJOR DIVISIONS			SYMBOLS		TYPICAL DESCRIPTIONS
			GRAPH	LETTER	
COARSE GRAINED SOILS MORE THAN 50% OF MATERIAL IS LARGER THAN NO. 200 SIEVE SIZE	GRAVEL AND GRAVELLY SOILS	CLEAN GRAVELS (LITTLE OR NO FINES)		GW	Well-graded gravels, gravel sand mixtures, little or no fines.
		GRAVELS WITH FINES (APPRECIABLE AMOUNT OF FINES)		GP	Poorly graded gravels, gravel-sand mixtures, little or no fines.
				GM	Silty gravels, gravel-sand-silt mixtures.
	SAND AND SANDY SOILS	CLEAN SANDS (LITTLE OR NO FINES)		SW	Well-graded sands, gravelly sands, little or no fines.
		SANDS WITH FINES (APPRECIABLE AMOUNT OF FINES)		SM	Silty sands, sand-silt mixtures.
				SC	Clayey sands, sand-clay mixtures.
FINE GRAINED SOILS MORE THAN 50% OF MATERIAL IS SMALLER THAN NO. 200 SIEVE SIZE	SILTS AND CLAYS	LIQUID LIMIT LESS THAN 50		ML	Inorganic silts and very fine sands, rock flour, silty or clayey fine sands or clayey silts with slight plasticity.
				CL	Inorganic clays of low to medium plasticity, gravelly clays, sandy clays, silty clays, lean clays.
				OL	Organic silts and organic silty clays of low plasticity.
	SILTS AND CLAYS	LIQUID LIMIT GREATER THAN 50		MH	Inorganic silts, micaceous or diatomaceous fine sandy or silty soils, elastic silts.
				CH	Inorganic clays of high plasticity, fat clays.
			OH	Organic clays of medium to high plasticity, organic silts.	
HIGHLY ORGANIC SOILS				PT	Peat and other highly organic soils.

NOTE: DUAL SYMBOLS ARE USED TO INDICATE BORDERLINE SOIL CLASSIFICATIONS

Notes

See Soil Boring Information Special Provision.

SPT (Standard Penetration Test-ASTM D1586):

The number of blows of a 140 lb (63.6 kg) hammer falling 2.5 ft (750 mm) used to drive a 2 in (50 mm)

O.D. Split Spoon sampler for a total of 1.5 ft (0.45 m) of penetration.

Written as follows:

first 0.5 ft (0.15 m) - second 0.5 ft (0.15 m) - third 0.5 ft (0.15 m)

(ex: 1-3-9)

Note: if the number of blows exceeds 50 before 0.5 ft (0.15 m) of penetration is achieved, the actual penetration rounded to the nearest 0.1 ft (0.03 m) follows the number of blows in parentheses (ex: 12-24-50 (0.09 m), 34-50 (0.4 ft), or 100 (0.3 ft)). WR denotes a zero blow count with the weight of the rods only.

WH denotes a zero blow count with the weight of the rods plus the weight of the hammer.

MC=Moisture Content, LL=Liquid limit, PL=Plastic Limit
-200%=percent soil passing 200 sieve, DD=Dry Density

Soil Classifications are Based on the Unified Soil Classification System, ASTM D2487 and D2488. Also included are the AASHTO group classifications (M145). Descriptions are based on visual observation, except where they have been modified to reflect results of laboratory tests as deemed appropriate.

Example soil description: Sandy FAT CLAY (CH), soft, wet, brown. (A-7)

Order of Descriptors

- Group Name
- Consistency or Relative Density
- Moisture Condition
- Color
- Particle size descriptor(s) (coarse grained soils only)
- Angularity of coarse grained soils
- Other relevant notes

Criteria For Descriptors

Consistency of Fine Grained Soils

Consistency	N-Value (uncorrected)
Very Soft	< 2
Soft	2 - 4
Medium Stiff	5 - 8
Stiff	9 - 15
Very Stiff	16 - 30
Hard	> 30

Apparent Density of Coarse Grained Soils

Relative Density	N-Value (uncorrected)
Very Loose	< 4
Loose	4 - 10
Medium Dense	11 - 30
Dense	31 - 50
Very Dense	> 50

Moisture Condition

- Dry -Absence of moisture, dusty, dry to the touch.
- Moist -Damp, but no visible water.
- Wet -Visible free water.

Definition of Particle Size Ranges

Soil Component	Size Range
Boulder	> 12 in (300 mm)
Cobble	3 in (75 mm) - 12 in (300 mm)
Gravel	No. 4 Sieve (4.75 mm) to 3 in (75 mm)
Sand	No. 200 (0.075 mm) to No. 4 Sieves (4.75 mm)
Silt	< No. 200 Sieve (0.075 mm)*
Clay	< No. 200 Sieve (0.075 mm)*

*Atterberg limits and chart below to differentiate between silt and clay.

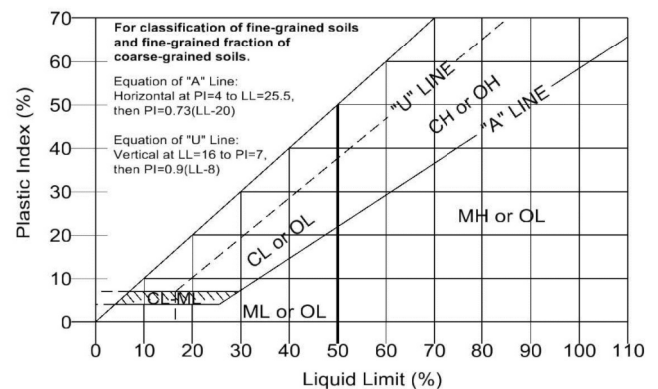

Angularity of Coarse-Grained Particles

- Angular -Particles have sharp edges and relative plane sides with unpolished surfaces.
- Subangular -Particles are similar to angular description, but have rounded edges.
- Subrounded-Particles have nearly plane sides, but have no edges.
- Rounded -Particles have smoothly curved sides and well-rounded corners and edges.

Tetra Tech Boring Log Descriptive Terminology

Key to Rock Symbols and Terms

12/06/12



Rock Type	Symbol	Rock Type	Symbol	Rock Type	Symbol
Argillite		Dolomite		Quartzite	
Basalt		Gneiss		Rhyolite	
Bedrock (other)		Granitic		Sandstone	
Breccia		Limestone		Schist	
Claystone		Siltstone		Shale	
		Conglomerate			

Order of Descriptors

- Rock Type
- Color
- Grain size (if applicable)
- Stratification/Foliation (as applicable)
- Field Hardness
- Other relevant notes

Criteria For Descriptors

Grain Size

Description	Characteristic
Coarse Grained	-Individual grains can be easily distinguished by eye
Fine Grained	-Individual grains can be distinguished with difficulty

Stratum Thickness

Thickly Bedded	3-10 ft (1-3 m)
Medium Bedded	1-3 ft (300 mm - 1 m)
Thinly Bedded	2-12 in (50-300 mm)
Very Thinly Bedded	< 2 in (50 mm)

Rock Field Hardness

Very Soft	-Can be carved with knife. Can be excavated readily with point of rock hammer. Can be scratched readily by fingernail.
Soft	-Can be grooved or gouged readily by knife or point of rock hammer. Can be excavated in fragments from chips to several inches in size by moderate blows of the point of a rock hammer.
Medium	-Can be grooved or gouged 0.05 in (2 mm) deep by firm pressure of knife or rock hammer point. Can be excavated in small chips to pieces about 1 in (25 mm) maximum size by hard blows of the point of a rock hammer.
Moderately hard	-Can be scratched with knife or pick. Gouges or grooves to 0.25 in (6 mm) can be excavated by hard blow of rock hammer. Hand specimen can be detached by moderate blows.
Hard	-Can be scratched with knife or pick only with difficulty. Hard hammer blows required to detach hand specimen.
Very Hard	-Cannot be scratched with knife or sharp rock hammer point. Breaking of hand specimens requires several hard blows of a rock hammer.

Notes:

UCS = Unconfined Compressive Strength obtained from laboratory testing at the given depth.

See Soil Boring Information Special Provision.

Miscellaneous Soil/Rock Symbols and Terms

	Concrete
	Asphalt
	Water
	Boulders and Cobbles
	Coal
	Fill
	Millings
	Topsoil

Explanation of Text Fields In Boring Logs:

Material Description: Lithologic Description of soil or rock encountered.

Remarks: Comments on drilling, including method, bit type, and problems encountered.
Unless stated on logs as being surveyed by district survey, all locations are considered approximate.

General Notes

- Descriptions on these boring logs apply only at the specific boring, and at the time the borings were made. These logs are not warranted to be representative of subsurface conditions at other locations or times.
- Water level observations apply only at the specific boring, and at the time the borings were made. Due to the variability of groundwater measurements given the type of drilling used, and the stratification of the soil in the boring, these logs are not warranted to be representative of groundwater conditions at other locations or times.
- Other terms may be used as descriptors, as defined by the profession.

Operation Types:

	Auger
	Casing Advancer
	Core Barrel
	Drive Casing

Sample Types:

	Split Spoon
	Shelby
	Bulk Sample
	Grab Sample
	Cone Penetrometer
	Vane Shear
	Special Samplers
	Testpit

-Soil and Rock descriptions are based on visual observation, except where they have been modified to reflect results of laboratory tests as deemed appropriate.

Example Rock Log

SANDSTONE, gray, fine grained, thickly bedded, hard field hardness.



CLASSIFICATION OF SOILS FOR ENGINEERING PURPOSES

ASTM Designation: D 2487 – 83
(Based on Unified Soil Classification System)

MAJOR DIVISIONS		GROUP SYMBOL	GROUP NAME
Coarse-Grained Soils More than 50% retained on No. 200 sieve	Gravels More than 50% coarse fraction retained on No. 4 sieve	Clean Gravels Less than 5% fines $Cu \geq 4$ and $1 \leq Cc \leq 3^E$	GW Well graded gravel ^F
		$Cu < 4$ and/or $1 > Cc > 3^E$	GP Poorly graded gravel ^F
		Gravels with Fines More than 12% fines Fines classify as ML or MH	GM Silty gravel ^{F GH}
		Fines classify as CL or CH	GC Clayey gravel ^{F GH}
	Sands 50% or more of coarse fraction passes No. 4 sieve	Clean Sands Less than 5% fines $Cu \geq 6$ and $1 \leq Cc \leq 3^E$	SW Well-graded sand ^I
		$Cu < 6$ and/or $1 > Cc > 3^E$	SP Poorly graded sand ^I
		Sands with Fines More than 12% fines Fines classify as ML or MH	SM Silty Sand ^{G HI}
		Fines classify as CL or CH	SC Clayey sand ^{G HI}
Fine-Grained Soils 50% or more passes the No. 200 sieve	Silts and Clays Liquid limit less than 50	Inorganic PI > 7 and plots on or above "A" line	CL Lean clay ^{KLM}
		Inorganic PI < 4 or plots below "A" line	ML Silt ^{KLM}
	Silts and Clays Liquid limit 50 or more	Organic $\frac{\text{Liquid limit} - \text{oven dried}}{\text{Liquid limit} - \text{not dried}} < 0.75$	OL Organic clay ^{KLMN} Organic silt ^{KLM O}
		Inorganic PI plots on or above "A" line	CH Fat clay ^{KLM}
		Inorganic PI plots below "A" line	MH Elastic silt ^{KLM}
		Organic $\frac{\text{Liquid limit} - \text{oven dried}}{\text{Liquid limit} - \text{not dried}} < 0.75$	OH Organic clay ^{KLM O} Organic silt ^{KLM O}
Highly organic soils	Primarily organic matter, dark in color, and organic odor	PT	Peat

^A Based on the material passing the 3-in. (75-mm) sieve.

^B If field sample contained cobbles or boulders, or both, add "with cobbles or boulders, or both" to group name.

^C Gravels with 5 to 12% require dual symbols:
GW-GM well-graded gravel with silt
GW-GC well-graded gravel with clay
GP-GM poorly graded gravel with silt
GP-GC poorly graded gravel with clay

^D Sands with 5 to 12% fines require dual symbols:
SW-SM well-graded sand with silt
SW-SC well-graded sand with clay
SP-SM poorly graded sand with silt
SP-SC poorly graded sand with clay

^E $Cu = D_{60}/D_{10}$ $Cc = (D_{30})^2 / (D_{10} \times D_{60})$

^F If soil contains $\geq 15\%$ sand, add "with sand" to group name.

^G If fines classify as CL-ML, use dual symbol GC-GM, or SC-SM.

^H If fines are organic, add "with organic fines" to group name.

^I If soil contains $\geq 15\%$ gravel, add "with gravel" to group name.
If soil contains $\geq 15\%$ gravel, add "with gravel" to group name.

^J If Atterberg limits plot in hatched area, soil is a CL-ML, silty clay.

^K If soil contains 15 to 29% plus No. 200, add "with sand" or "with gravel", whichever is predominant.

^L If solid contains $\geq 30\%$ plus No. 200, predominantly sand, add "sandy" to group name.

^M If soil contains $\geq 30\%$ plus No. 200, predominantly gravel, add "gravelly" to group name.

^N PI ≥ 4 and plots on or above "A" line.

^O PI < 4 or plots below "A" line.

^P PI plots on or above "A" line.

^Q PI plots below "A" line.

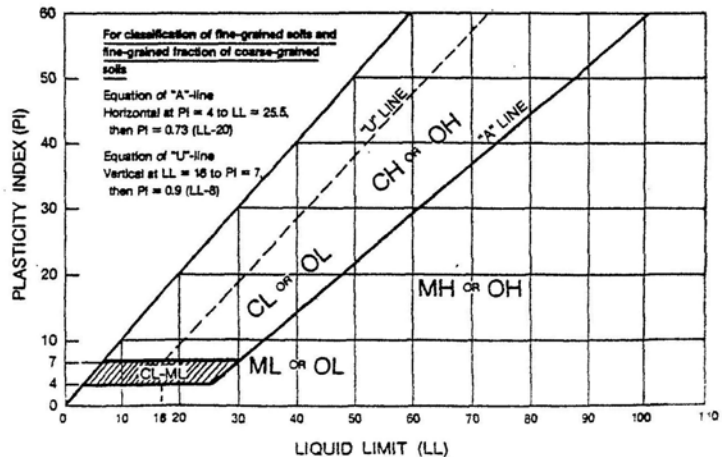
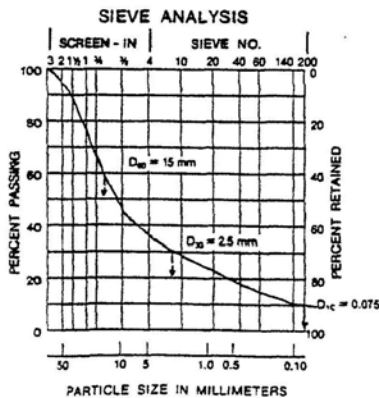

$$C_u = \frac{D_{60}}{D_{10}} = \frac{15}{0.075} = 200 \quad C_c = \frac{(D_{30})^2}{D_{12} \times 10_{36}} + \frac{(2.5)}{0.075 \times 15} = 5.6$$

Boring 23-01

Project: Grant Chamberlain and Paisley Court Parking Lot Rebuild		Rig: Mobile B60X Hammer: Auto	Boring Location N: 45.670525 Coordinates E: -111.060337
Project Number: 117-8598103		Boring Diameter: 8"	System: Decimal Degrees Datum: WGS84 Top of Boring Elevation: 4865.0 ft
Date Started: 3/29/23	Date Finished: 3/29/23	Drilling Fluid: None	Abandonment Method: Backfilled with Cuttings
Driller: O'Keefe Logger: Treven Hembree		Location: Grant Chamberlain. See Site Map	

TT LOG OF BORING - MDT REVISED 2009+.GDT - 4/24/23 11:23 - \\TT.LOCAL\GFS\USVOLUME4\LEGACY\TT5079F51\DATA\GEGOTECH\REPORTS\REPORT 2023\MSU STREETS & PARKING\LAB LOGS\BORING LOGS.GPJ

Depth (ft) Elev. (ft)	Operation	Sample Type	Recovery (%)	RQD (%)	Blow Count	Lithology	Material Description	Depth (ft) Elev. (ft)	MC (%)	LL	PL	-200 (%)	DD	Remarks and Other Tests
1 4864.0			10		11 - 9 - 9	Asphalt, 3-inches thick.	0.3 4864.7							
2 4863.0						FILL, Clayey GRAVEL with sand (GC), moist, Frozen.	1.0 4864.0		25	17	13			
3 4862.0			100		6 - 12 - 23	Sandy Lean CLAY (CL), moist to wet, tan, fine grained, low plasticity, Frozen, Vx to Nbe.	4.0 4861.0							
4 4861.0						Poorly-Graded GRAVEL with sand (GP), moist, gray, medium to coarse grained, subrounded, Frozen.	6.5 4858.5							
5 4860.0														
6 4859.0			70		16 - 25 - 36									
Boring Depth: 6.5 ft, Elevation: 4858.5 ft														

Water Level Observations	<input type="checkbox"/> During Drilling: Not Encountered <input checked="" type="checkbox"/> After Drilling: Not Recorded	Remarks:
<input checked="" type="checkbox"/> After Drilling: Not Recorded	<input checked="" type="checkbox"/> After Drilling: Not Recorded	

Boring 23-02

Project: Grant Chamberlain and Paisley Court Parking Lot Rebuild		Rig: Mobile B60X Hammer: Auto	Boring Location N: 45.669589 Coordinates E: -111.060834
Project Number: 117-8598103		Boring Diameter: 8"	System: Decimal Degrees Datum: WGS84 Top of Boring Elevation: 4867.0 ft
Date Started: 3/29/23	Date Finished: 3/29/23	Drilling Fluid: None	Abandonment Method: Backfilled with Cuttings
Driller: O'Keefe Logger: Treven Hembree		Location: Grant Chamberlain. See Site Map	

TT LOG OF BORING - MDT REVISED - 2009+ - GDT - 4/24/23 11:23 - \\ITT.LOCAL\GFS\USVOLUME4\LEGACY\TTS079FS1\DATA\GEGEOTECH\REPORTS\REPORT 2023\MSU STREETS & PARKING\LAB LOGS\BORING LOGS.GPJ

Depth (ft) Elev. (ft)	Operation	Sample Type	Recovery (%)	RQD (%)	Blow Count	Lithology	Material Description	Depth (ft) Elev. (ft)	MC (%)	LL	PL	-200 (%)	DD	Remarks and Other Tests
0.3 4866.7			30		9 - 7 - 8	Asphalt, 3-inches thick.								
1.0 4866.0						FILL, Clayey GRAVEL with sand (GC), moist, brown to black, fine to coarse grained, subangular, Frozen.								
1.0 4866.0						Sandy Lean CLAY (CL), moist to wet, tan, fine grained, low plasticity, Frozen, Vx to Nbe.								
3.0 4864.0			60		20 - 30 - 23	Poorly-Graded GRAVEL with sand (GP), moist, gray, medium to coarse grained, subrounded, Frozen.								
6.5 4861.0			70		11 - 19 - 15									
Boring Depth: 6.5 ft, Elevation: 4860.5 ft														

Water Level Observations	<input type="checkbox"/> During Drilling: Not Encountered <input checked="" type="checkbox"/> After Drilling: Not Recorded	Remarks:
<input checked="" type="checkbox"/> After Drilling: Not Recorded	<input checked="" type="checkbox"/> After Drilling: Not Recorded	

Boring 23-03

Project: Grant Chamberlain and Paisley Court Parking Lot Rebuild		Rig: Mobile B60X Hammer: Auto	Boring Location N: 45.669645 Coordinates E: -111.057737
Project Number: 117-8598103		Boring Diameter: 8"	System: Decimal Degrees Datum: WGS84 Top of Boring Elevation: 4870.0 ft
Date Started: 3/29/23	Date Finished: 3/29/23	Drilling Fluid: None	Abandonment Method: Backfilled with Cuttings
Driller: O'Keefe Logger: Treven Hembree		Location: Grant Chamberlain. See Site Map	

TT LOG OF BORING - MDT REVISED 2009+.GDT - 4/24/23 11:23 - \\ITT.LOCAL\GFS\USVOLUME4\LEGACY\TT5079FS1\DATA\GEGOTECH\REPORTS\REPORT 2023\MSU STREETS & PARKING\LAB LOGS\BORING LOGS.GPJ

Depth (ft) Elev. (ft)	Operation	Sample Type	Recovery (%)	RQD (%)	Blow Count	Lithology	Material Description	Depth (ft) Elev. (ft)	MC (%)	LL	PL	-200 (%)	DD	Remarks and Other Tests
0.2 4869.8			50		6 - 6 - 5	Asphalt, 2-inches thick.								
1.0 4869.0						FILL, Clayey GRAVEL with sand (GC), moist, Frozen.								
1.0 4869.0						Sandy Lean CLAY (CL), moist to wet, tan, fine grained, low plasticity, Frozen, Vx to Nbe.			31	18	60	111		
3.0 4867.0			90		3 - 2 - 6									
5.0 4865.0						Poorly-Graded GRAVEL with sand (GP), moist, gray, medium to coarse grained, subrounded, Frozen.								
5.0 4865.0			5		18 - 38 - 35									
6.5 4863.5														

Boring Depth: 6.5 ft, Elevation: 4863.5 ft

Water Level Observations	<input type="checkbox"/> During Drilling: Not Encountered <input checked="" type="checkbox"/> After Drilling: Not Recorded	Remarks:
<input checked="" type="checkbox"/> After Drilling: Not Recorded	<input checked="" type="checkbox"/> After Drilling: Not Recorded	

Boring 23-04

Project: Grant Chamberlain and Paisley Court Parking Lot Rebuild		Rig: Mobile B60X Hammer: Auto	Boring Location N: 45.670553 Coordinates E: -111.058182
Project Number: 117-8598103		Boring Diameter: 8"	System: Decimal Degrees Datum: WGS84 Top of Boring Elevation: 4866.0 ft
Date Started: 3/29/23	Date Finished: 3/29/23	Drilling Fluid: None	Abandonment Method: Backfilled with Cuttings
Driller: O'Keefe Logger: Treven Hembree		Location: Grant Chamberlain. See Site Map	

TT LOG OF BORING - MDT - REVISED - 2009+.GDT - 4/24/23 11:23 - \\ITT.LOCAL\GFS\USVOLUME4\LEGACY\TT5079FS1\DATA\GECOTECH\REPORTS\REPORT 2023\MSU STREETS & PARKING\LAB LOGS\BORING LOGS.GPJ

Depth (ft) Elev. (ft)	Operation	Sample Type	Recovery (%)	RQD (%)	Blow Count	Lithology	Material Description	Depth (ft) Elev. (ft)	MC (%)	LL	PL	-200 (%)	DD	Remarks and Other Tests
1 4865.0			65		9 - 5 - 5		Asphalt, 4-inches thick.	0.4 4865.6						
2 4864.0							FILL, Clayey GRAVEL with sand (GC), moist, fine to coarse grained, Frozen.	1.4 4864.6						
3 4863.0			10		16 - 14 - 10		Sandy Lean CLAY (CL), moist to wet, tan, fine grained, low plasticity, Frozen, Vx to Nbe.							
4 4862.0														
5 4861.0														
6 4860.0			0		18 - 39 - 41		Poorly-Graded GRAVEL with sand (GP), moist, gray, medium to coarse grained, subrounded, Frozen.	5.0 4861.0						
Boring Depth: 6.5 ft, Elevation: 4859.5 ft								6.5 4859.5						

Water Level Observations	<input type="checkbox"/> During Drilling: Not Encountered <input checked="" type="checkbox"/> After Drilling: Not Recorded	Remarks:
<input checked="" type="checkbox"/> After Drilling: Not Recorded	<input checked="" type="checkbox"/> After Drilling: Not Recorded	

Boring 23-05

Project: Grant Chamberlain and Paisley Court Parking Lot Rebuild		Rig: Mobile B60X Hammer: Auto	Boring Location N: 45.667194 Coordinates E: -111.058465
Project Number: 117-8598103		Boring Diameter: 8"	System: Decimal Degrees Datum: WGS84 Top of Boring Elevation: 4881.0 ft
Date Started: 3/29/23	Date Finished: 3/29/23	Drilling Fluid: None	Abandonment Method: Backfilled with Cuttings
Driller: O'Keefe Logger: Treven Hembree		Location: Paisley Court East. See Site Map	

TT LOG OF BORING - MDT REVISED_2009+.GDT - 4/24/23 11:23 - \\IT.LOCAL\GFS\USVOL\ME4\LEGACY\TTS079F51\DATA\GEGE\TECH\REPORTS\REPORT 2023\MSU STREETS & PARKING\LAB LOGS\BORING LOGS.GPJ

Depth (ft) Elev. (ft)	Operation	Sample Type	Recovery (%)	RQD (%)	Blow Count	Lithology	Material Description	Depth (ft) Elev. (ft)	MC (%)	LL	PL	-200 (%)	DD	Remarks and Other Tests
1 4880.0			100		7 - 4 - 7	Asphalt, 3.5-inches thick.	0.3 4880.7							
2 4879.0						FILL, Poorly-Graded GRAVEL with sand (GP), moist, fine to coarse grained, Frozen.	1.0 4880.0							
3 4878.0			95		6 - 7 - 12	Sandy Lean CLAY (CL), moist to wet, tan, fine grained, low plasticity, Frozen, Vx to Nbe.								
4 4877.0														
5 4876.0														
6 4875.0			100		25 - 28 - 32	Poorly-Graded GRAVEL with sand (GP), moist, gray, medium to coarse grained, subrounded, Frozen.	5.5 4875.5							
							6.5 4874.5							





Boring Depth: 6.5 ft, Elevation: 4874.5 ft

Water Level Observations	<input type="checkbox"/> During Drilling: Not Encountered <input checked="" type="checkbox"/> After Drilling: Not Recorded	Remarks:
<input checked="" type="checkbox"/> After Drilling: Not Recorded	<input checked="" type="checkbox"/> After Drilling: Not Recorded	

Boring 23-06

Project: Grant Chamberlain and Paisley Court Parking Lot Rebuild		Rig: Mobile B60X Hammer: Auto	Boring Location N: 45.667053 Coordinates E: -111.059064
Project Number: 117-8598103		Boring Diameter: 8"	System: Decimal Degrees Datum: WGS84 Top of Boring Elevation: 4882.0 ft
Date Started: 3/29/23	Date Finished: 3/29/23	Drilling Fluid: None	Abandonment Method: Backfilled with Cuttings
Driller: O'Keefe Logger: Treven Hembree		Location: Paisley Court East. See Site Map	

TT LOG OF BORING - MDT REVISED_2009+.GDT - 4/24/23 11:23 - \\ITT.LOCAL\GFS\USVOL\ME4\LEGACY\TT\2079FS1\DATA\GEO\TECH\REPORTS\REPORT 2023\MSU STREETS & PARKING\LAB LOGS\BORING LOGS.GPJ

Depth (ft) Elev. (ft)	Operation	Sample Type	Recovery (%)	RQD (%)	Blow Count	Lithology	Material Description	Depth (ft) Elev. (ft)	MC (%)	LL	PL	-200 (%)	DD	Remarks and Other Tests
1 4881.0			100		14 - 11 - 11		Asphalt, 3-inches thick.	0.3 4881.7						
2 4880.0							FILL, Clayey GRAVEL with sand (GC), moist, fine to coarse grained, Frozen.	0.8 4881.2		21	16	14		
3 4879.0			100		6 - 7 - 10		Sandy Lean CLAY (CL), moist to wet, tan, fine grained, low plasticity, Frozen, Vx to Nbe.							
4 4878.0														
5 4877.0														
6 4876.0			85		5 - 43 - 37		Poorly-Graded GRAVEL with sand (GP), moist, gray, medium to coarse grained, subrounded, Frozen.	5.5 4876.5						
Boring Depth: 6.5 ft, Elevation: 4875.5 ft								6.5 4875.5						

Water Level Observations	<input type="checkbox"/> During Drilling: Not Encountered <input checked="" type="checkbox"/> After Drilling: Not Recorded	Remarks:
<input checked="" type="checkbox"/> After Drilling: Not Recorded	<input checked="" type="checkbox"/> After Drilling: Not Recorded	

Boring 23-07

Project: Grant Chamberlain and Paisley Court Parking Lot Rebuild		Rig: Mobile B60X Hammer: Auto	Boring Location N: 45.667092 Coordinates E: -111.06025
Project Number: 117-8598103		Boring Diameter: 8"	System: Decimal Degrees Datum: WGS84 Top of Boring Elevation: 4882.0 ft
Date Started: 3/29/23	Date Finished: 3/29/23	Drilling Fluid: None	Abandonment Method: Backfilled with Cuttings
Driller: O'Keefe Logger: Treven Hembree		Location: Paisley Court West. See Site Map	

TT LOG OF BORING - MDT REVISED 2009+.GDT - 4/24/23 11:23 - \\TT.LOCAL\GFS\USVOLUME4\LEGACY\TT5079FS1\DATA\GEGE\TECH\REPORTS\REPORT 2023\MSU STREETS & PARKING\LAB LOGS\BORING LOGS.GPJ

Depth (ft) Elev. (ft)	Operation	Sample Type	Recovery (%)	RQD (%)	Blow Count	Lithology	Material Description	Depth (ft) Elev. (ft)	MC (%)	LL	PL	-200 (%)	DD	Remarks and Other Tests
0.1 4881.9			90		8 - 12 - 9		Asphalt, 1-inch thick.	0.1 4881.9						
1.0 4881.0							FILL, Clayey GRAVEL with sand (GC), moist, fine to coarse grained, Frozen.	1.0 4881.0						
1.0 4880.0							Sandy Lean CLAY (CL), moist to wet, tan, fine grained, low plasticity, Frozen, Vx to Nbe.	1.0 4881.0						
3.5 4879.0			100		7 - 22 - 31		Poorly-Graded GRAVEL with sand (GP), moist, gray, medium to coarse grained, subrounded, Frozen.	3.5 4878.5						
6.5 4878.0							Poorly-Graded GRAVEL with sand (GP), moist, gray, medium to coarse grained, subrounded, Frozen.	6.5 4878.5						
6.5 4877.0			70		19 - 33 - 32			6.5 4877.0						
6.5 4876.0								6.5 4875.5						

Boring Depth: 6.5 ft, Elevation: 4875.5 ft

Water Level Observations	<input type="checkbox"/> During Drilling: Not Encountered <input checked="" type="checkbox"/> After Drilling: Not Recorded	Remarks:
<input checked="" type="checkbox"/> After Drilling: Not Recorded	<input checked="" type="checkbox"/> After Drilling: Not Recorded	

Boring 23-08

Project: Grant Chamberlain and Paisley Court Parking Lot Rebuild		Rig: Mobile B60X Hammer: Auto	Boring Location N: 45.667187 Coordinates E: -111.060943
Project Number: 117-8598103		Boring Diameter: 8"	System: Decimal Degrees Datum: WGS84 Top of Boring Elevation: 4882.0 ft
Date Started: 3/29/23	Date Finished: 3/29/23	Drilling Fluid: None	Abandonment Method: Backfilled with Cuttings
Driller: O'Keefe Logger: Treven Hembree		Location: Paisley Court West. See Site Map	

TT LOG OF BORING - MDT REVISED - 2009+.GDT - 4/24/23 11:23 - \\ITT.LOCAL\GFS\USVOLUME4\LEGACY\TT5079FS1\DATA\GEGEOTECH\REPORTS\REPORT 2023\MSU STREETS & PARKING\LAB LOGS\BORING LOGS.GPJ

Depth (ft) Elev. (ft)	Operation	Sample Type	Recovery (%)	RQD (%)	Blow Count	Lithology	Material Description	Depth (ft) Elev. (ft)	MC (%)	LL	PL	-200 (%)	DD	Remarks and Other Tests
0.2 4881.8					5 - 7 - 10	Asphalt, 2-inches thick.								
1.2 4880.8			60			FILL, Clayey GRAVEL with sand (GC), moist, fine to coarse grained, Frozen.								
1.2 4880.8					9 - 10 - 17	Sandy Lean CLAY (CL), moist to wet, gray to black, fine grained, low plasticity, Frozen, Vx to Nbe.			31	17	61	109		
5.0 4877.0			95			Poorly-Graded GRAVEL with sand (GP), moist, gray, medium to coarse grained, subrounded, Frozen.								
5.0 4877.0					24 - 60/0.5ft									
6.5 4875.5			50											
Boring Depth: 6.5 ft, Elevation: 4875.5 ft														

Water Level Observations	<input type="checkbox"/> During Drilling: Not Encountered <input checked="" type="checkbox"/> After Drilling: Not Recorded	Remarks:
<input checked="" type="checkbox"/> After Drilling: Not Recorded	<input checked="" type="checkbox"/> After Drilling: Not Recorded	

APPENDIX B: LABORATORY TESTING

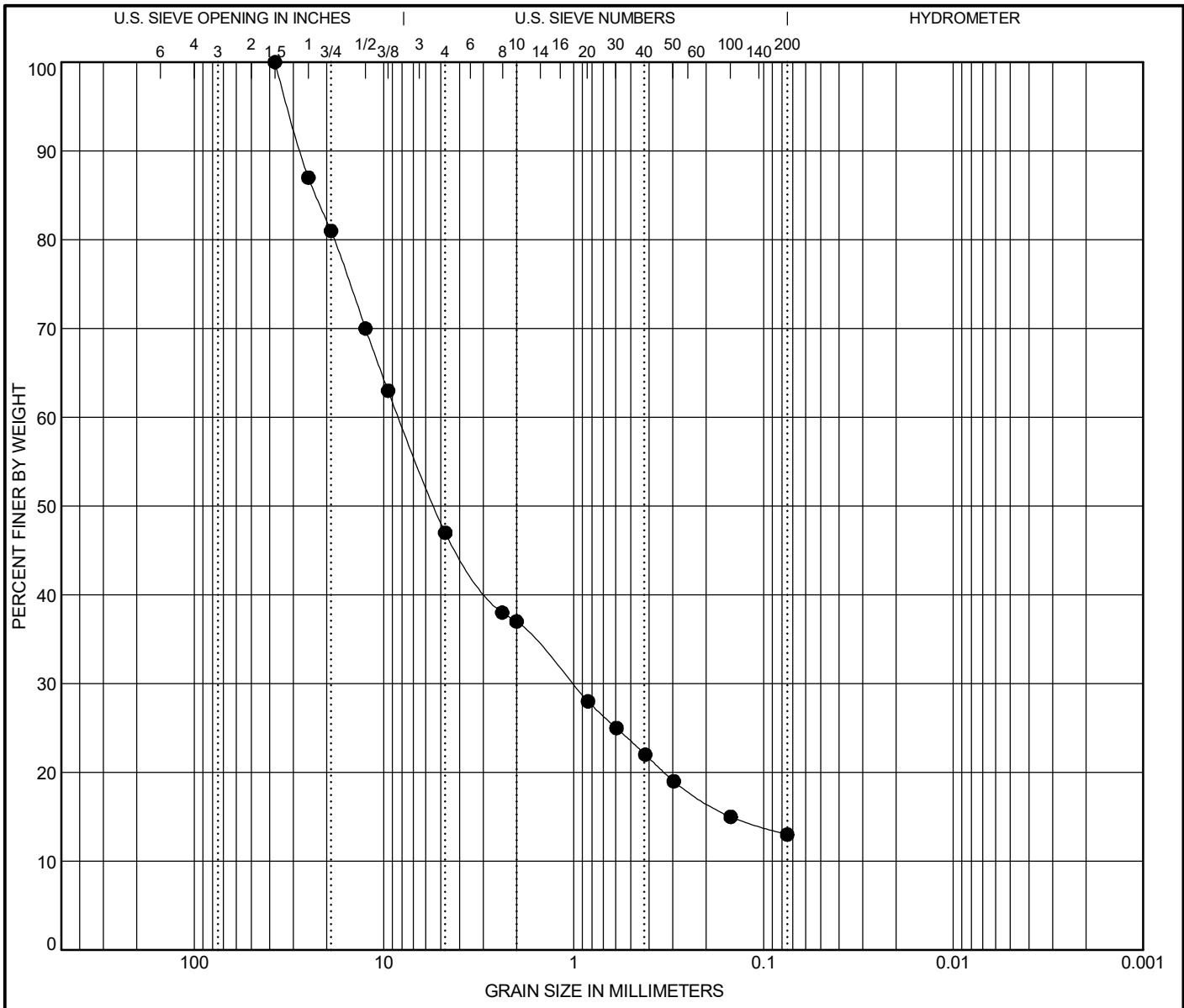

COBBLES	GRAVEL		SAND			SILT OR CLAY
	coarse	fine	coarse	medium	fine	

SIEVE SIZE	% PASSING
1.5 in	100
1 in	87
3/4 in	81
1/2 in	70
3/8 in	63
No. 4	47
No. 8	38
No. 10	37
No. 20	28
No. 30	25
No. 40	22
No. 50	19
No. 100	15
No. 200	13

Specimen Identification
23-01 - (1 - 2 ft)

Classification					
CLAYEY GRAVEL with SAND(GC)					
LL	PL	PI	Cc	Cu	
25	17	8			

% Gravel	% Sand	% Silt	% Clay
53	34	13	

D100	D60	D30	D10
37.5	8.342	1.02	

GRAIN SIZE DISTRIBUTION



Project: Grant Chamberlain and Paisley Court Parking Lot Rebuild
 Location: Grant Chamberlain. See Site Map
 Number: 117-8598103

Figure No. B-1

BORING LOGS.GPJ 4-24-23 TT_US GRAIN SIZE (SIEVE DATA)

Revised 1-23-08 (MAT)

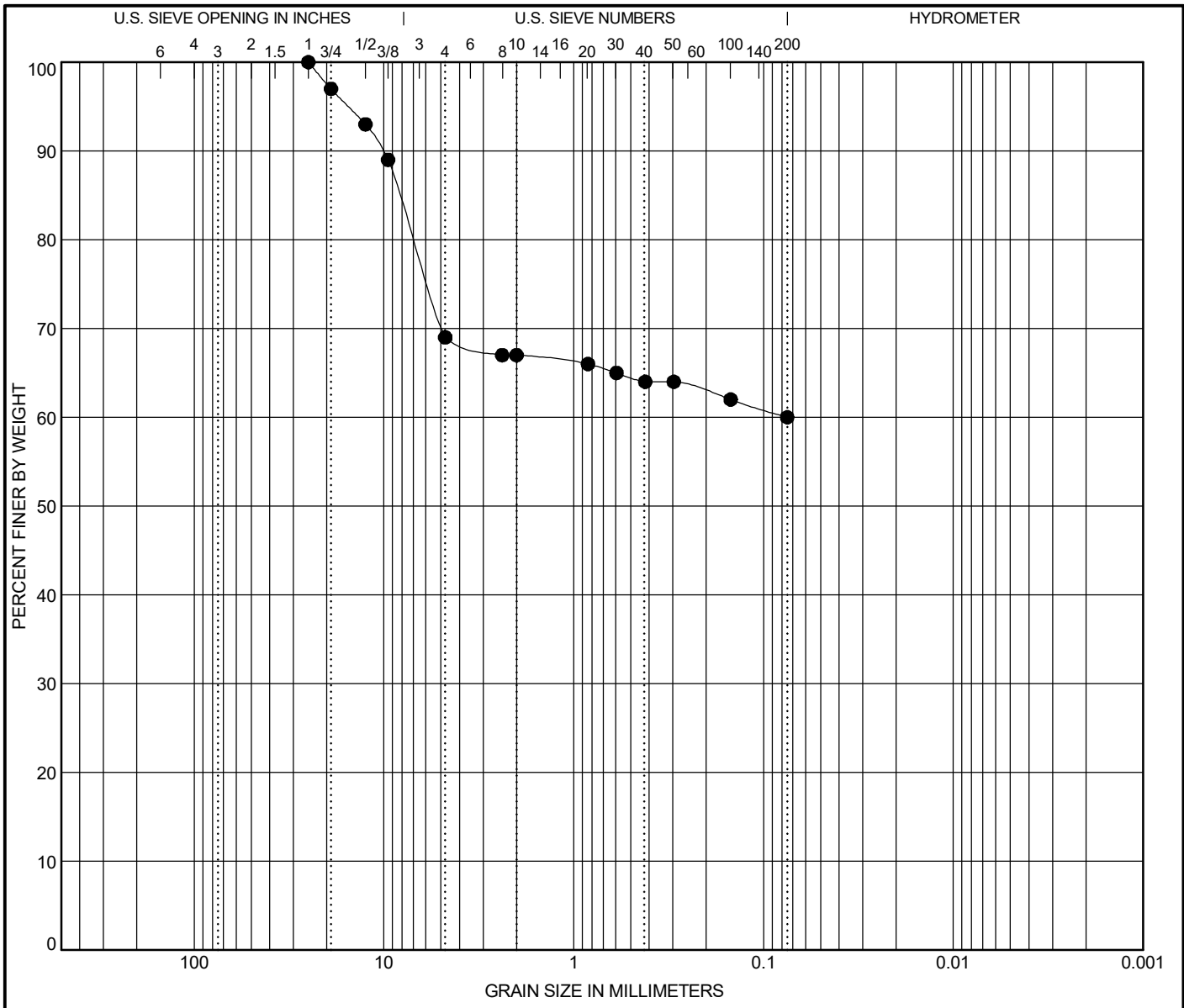

COBBLES	GRAVEL		SAND			SILT OR CLAY
	coarse	fine	coarse	medium	fine	

SIEVE SIZE	% PASSING
1 in	100
3/4 in	97
1/2 in	93
3/8 in	89
No. 4	69
No. 8	67
No. 10	67
No. 20	66
No. 30	65
No. 40	64
No. 50	64
No. 100	62
No. 200	60

Specimen Identification
23-03 - (2.5 - 4 ft)

Classification					
GRAVELLY LEAN CLAY(CL)					
LL	PL	PI	Cc	Cu	
31	18	13			

% Gravel	% Sand	% Silt	% Clay
31	9	60	

D100	D60	D30	D10
25	0.075		

GRAIN SIZE DISTRIBUTION



Project: Grant Chamberlain and Paisley Court Parking Lot Rebuild
 Location: Grant Chamberlain. See Site Map
 Number: 117-8598103

Figure No. B-2

BORING LOGS.GPJ 4-24-23 TT_US GRAIN SIZE (SIEVE DATA)

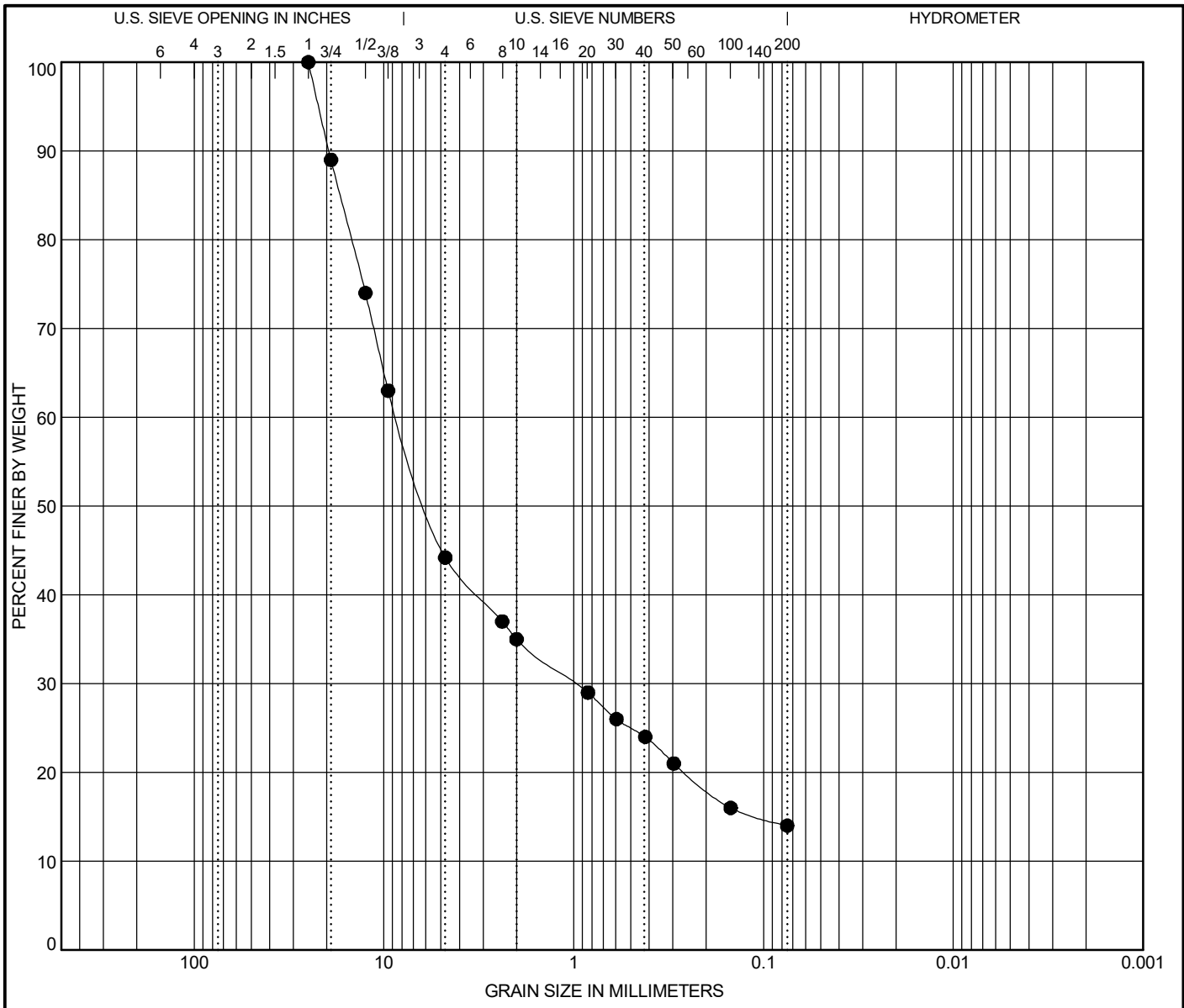

COBBLES	GRAVEL		SAND			SILT OR CLAY
	coarse	fine	coarse	medium	fine	

SIEVE SIZE	% PASSING
1 in	100
3/4 in	89
1/2 in	74
3/8 in	63
No. 4	44.2
No. 8	37
No. 10	35
No. 20	29
No. 30	26
No. 40	24
No. 50	21
No. 100	16
No. 200	14

Specimen Identification
23-06 - (1 - 2 ft)

Classification					
SILTY, CLAYEY GRAVEL with					
LL	PL	PI	Cc	Cu	
21	16	5			
SAND(GC-GM)					

% Gravel	% Sand	% Silt	% Clay
56	30	14	

D100	D60	D30	D10
25	8.505	0.972	

GRAIN SIZE DISTRIBUTION



Project: Grant Chamberlain and Paisley Court Parking Lot Rebuild
 Location: Paisley Court East. See Site Map
 Number: 117-8598103

Figure No. B-3

BORING LOGS.GPJ 4-24-23 TT_US GRAIN SIZE (SIEVE DATA)

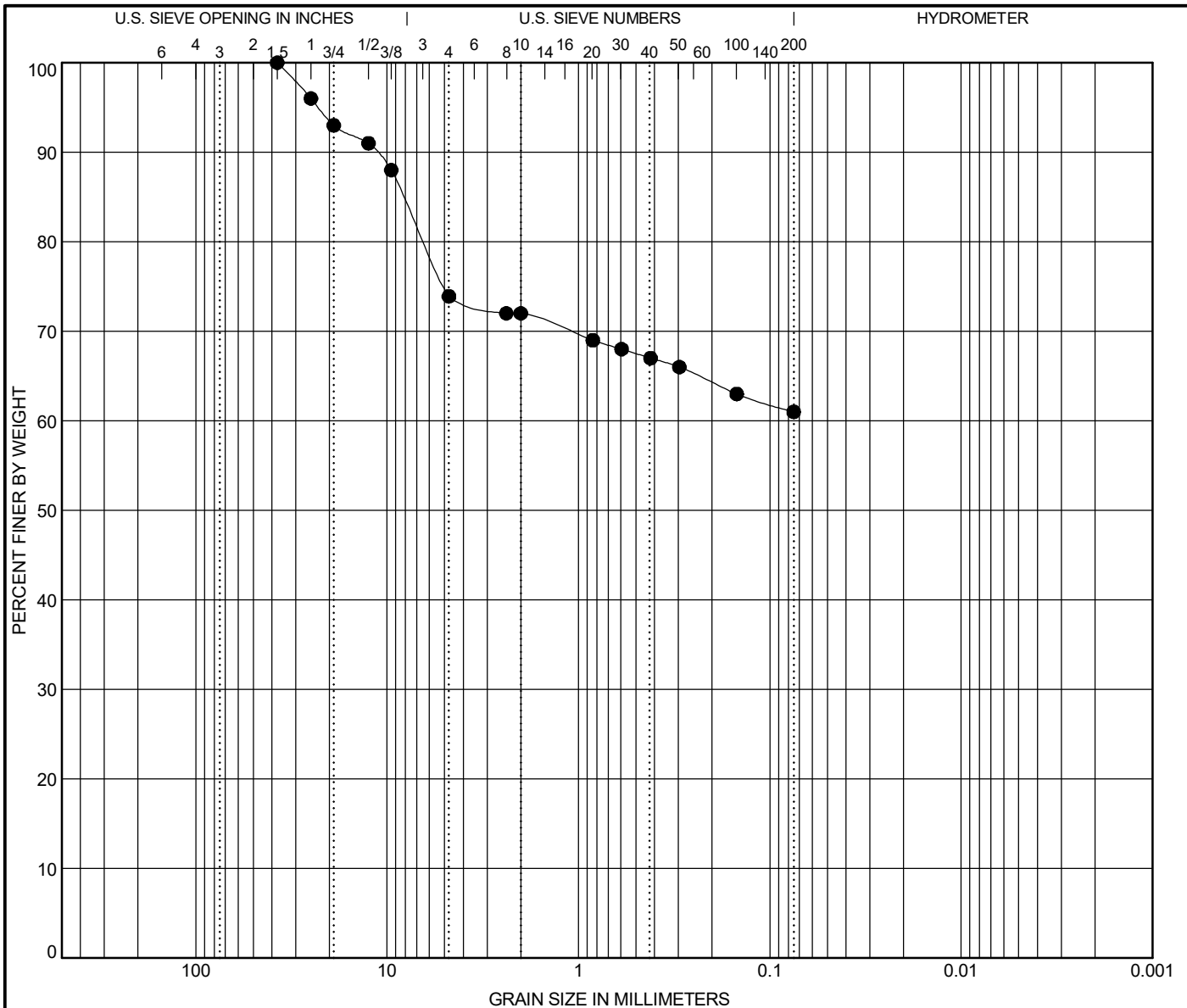

COBBLES	GRAVEL		SAND			SILT OR CLAY
	coarse	fine	coarse	medium	fine	

SIEVE SIZE	% PASSING
1.5 in	100
1 in	96
3/4 in	93
1/2 in	91
3/8 in	88
No. 4	73.9
No. 8	72
No. 10	72
No. 20	69
No. 30	68
No. 40	67
No. 50	66
No. 100	63
No. 200	61

Specimen Identification
23-08 - (2.5 - 4 ft)

Classification					
GRAVELLY LEAN CLAY(CL)					
LL	PL	PI	Cc	Cu	
31	17	14			

% Gravel	% Sand	% Silt	% Clay
26	13	61	

D100	D60	D30	D10
37.5			

GRAIN SIZE DISTRIBUTION

Project: Grant Chamberlain and Paisley Court Parking Lot Rebuild

Location: Paisley Court West. See Site Map

Number: 117-8598103

Figure No. B-4



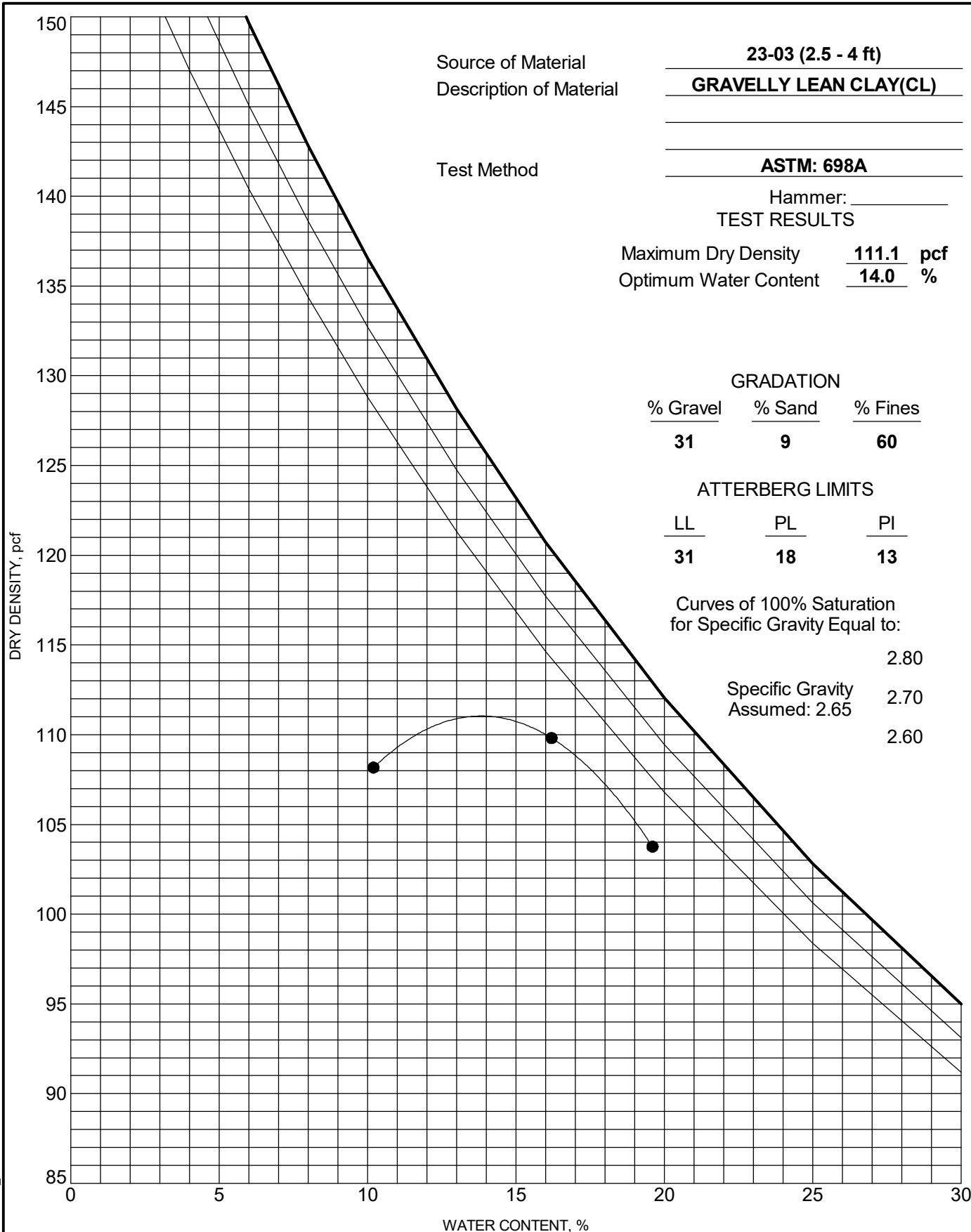

BORING LOGS.GPJ 4-24-23 TT_COMPACTON W/CURVE



MOISTURE-DENSITY RELATIONSHIP

Project: Grant Chamberlain and Paisley Court Parking Lot Rebuild

Location: Grant Chamberlain. See Site Map

Number: 117-8598103

Figure No. B-5

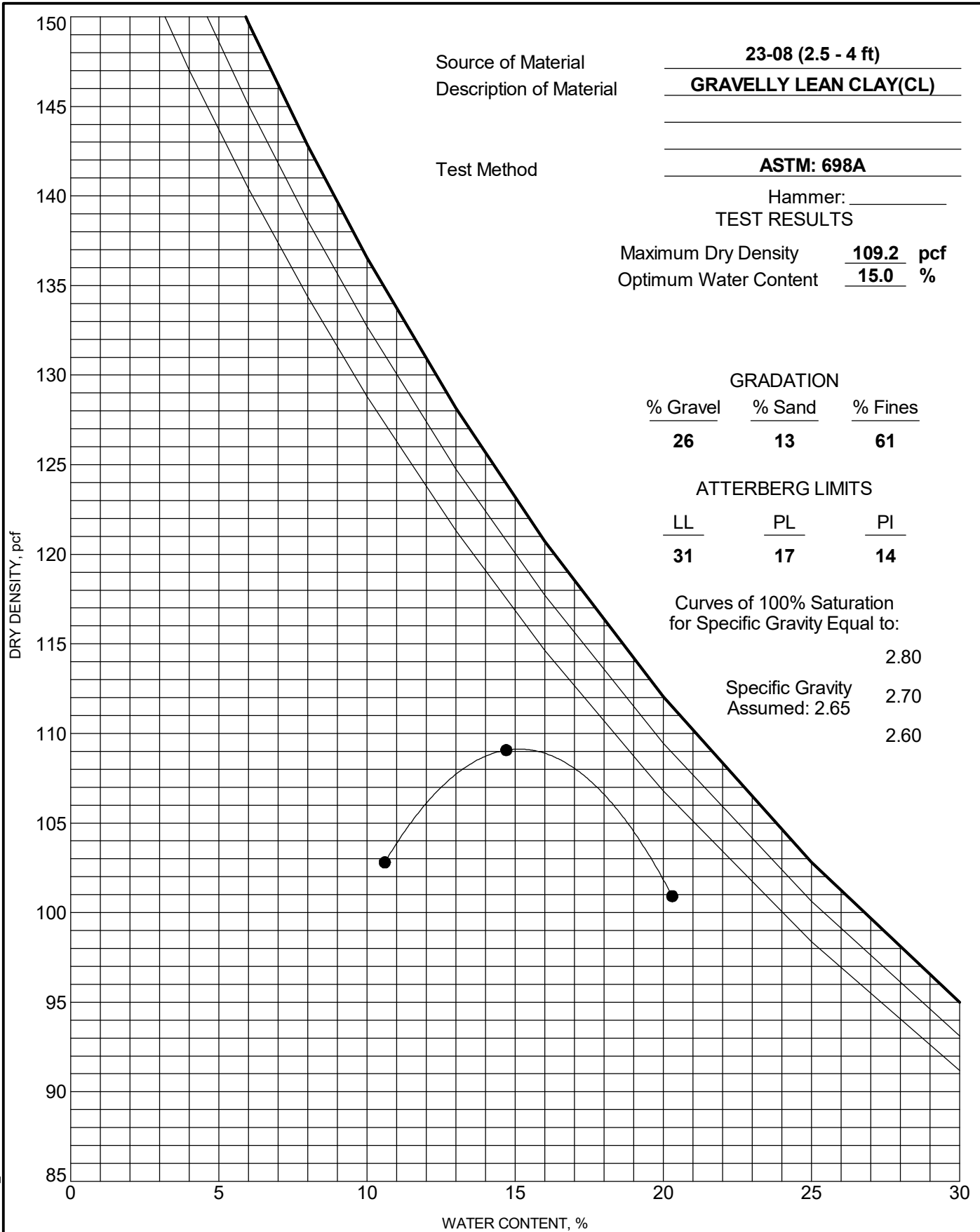

BORING LOGS.GPJ 4-24-23 TT_COMPACTON W/CURVE



MOISTURE-DENSITY RELATIONSHIP

Project: Grant Chamberlain and Paisley Court Parking Lot Rebuild

Location: Paisley Court West. See Site Map

Number: 117-8598103

Figure No. B-6

APPENDIX C: PHOTOGRAPHS



PROJECT NUMBER 117-8598103

PROJECT NAME Grant Chamberlain and Paisley Court Parking Lot Rebuild

23-01, Depth: 0 - 1.5



23-01, Depth: 2.5 - 4



23-01, Depth: 5 - 6.5



23-02, Depth: 0 - 1.5





PROJECT NUMBER 117-8598103

PROJECT NAME Grant Chamberlain and Paisley Court Parking Lot Rebuild

23-02, Depth: 2.5 - 4



23-02, Depth: 5 - 6.5



23-03, Depth: 0 - 1.5



23-03, Depth: 2.5 - 4





PROJECT NUMBER 117-8598103

PROJECT NAME Grant Chamberlain and Paisley Court Parking Lot Rebuild

23-03, Depth: 5 - 6.5



23-04, Depth: 0 - 1.5



23-04, Depth: 2.5 - 4

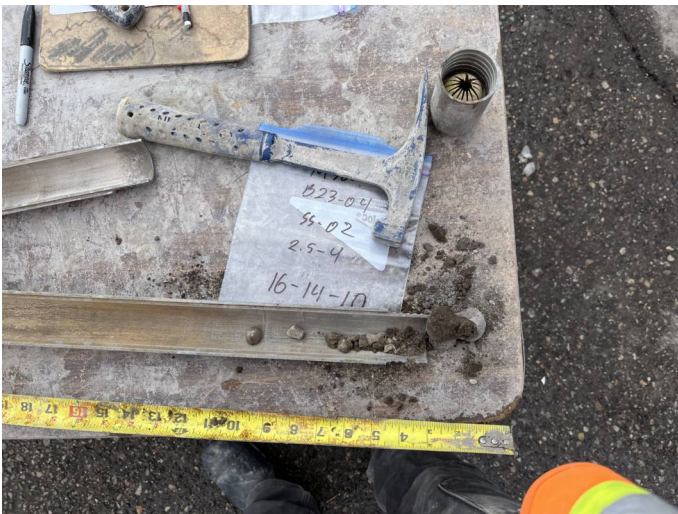

23-05, Depth: 0 - 1.5





PROJECT NUMBER 117-8598103

PROJECT NAME Grant Chamberlain and Paisley Court Parking Lot Rebuild

23-05, Depth: 2.5 - 4



23-05, Depth: 5 - 6.5



23-06, Depth: 0 - 1.5



23-06, Depth: 2.5 - 4





PROJECT NUMBER 117-8598103

PROJECT NAME Grant Chamberlain and Paisley Court Parking Lot Rebuild

23-06, Depth: 5 - 6.5



23-07, Depth: 0 - 1.5



23-07, Depth: 2.5 - 4



23-07, Depth: 5 - 6.5



APPENDIX D: RECLAMATION SPECIAL PROVISIONS

XXX. BITUMINOUS RECLAMATION

XXXI. Description

Furnish all labor, equipment and materials to reclaim the existing asphalt layer and base course in accordance with these specifications and to the lines, grades and details shown in the plans or as established by the Project Manager.

B. Materials

1. The reclaimed bituminous material shall meet the following gradation, i.e., approximately 5 percent of the reclaimed bituminous material can be between the 1.5-inch and 3 inch size following reclamation :

<u>Sieve Size</u>	<u>Percent Passing (by weight)</u>
4.0" (75mm)	100%
1.5" (25mm)	95%

C. EQUIPMENT

1. The Road Reclaimer – The Contractor shall furnish a self-propelled machine designed to blend together the in-place asphalt and aggregate structure. It shall be capable of uniformly blending the material to a depth of 12 inches. This machine shall have automatic depth and cross-slope controls and maintain a constant cutting depth. The automatic depth controls shall maintain the cutting depth to within plus or minus ¼ inch of the depth shown on the Plans.

D. Construction

A. Contractor Qualifications:

1. The bidder shall carefully examine the site of the proposed work and become thoroughly familiar with the existing site conditions, and the conditions of the contract. A geotechnical report for the project was prepared by Tetra Tech, Inc., dated April 14, 2021. The report gives a general overview of the subsurface conditions that may be encountered at the project site, not information on specific locations or variations in the subsurface stratigraphy. To better define subsurface conditions along the proposed alignment, potential bidders are encouraged to perform additional site visits or investigations, at no additional cost to the owner.
2. The Contractor performing the work described in this Specification shall have a minimum of 5 years of experience performing highway/roadway reclamation work with a minimum of three projects being 1 mile or greater in length. The contractor shall assign a supervisor with a minimum of 5 years of experience on

highway/roadway reclamation projects. The contractor may not use consultants or manufacturers representatives in order to meet the requirements of this section. Reclamation operators and on-site personnel shall have a minimum of three years of experience on highway/roadway reclamation projects.

E. Reclamation:

1. All vegetation and topsoil that is adjacent to the surface (mainline or shoulder) that is to be reclaimed shall be removed prior to the start of pulverization, as directed by the Engineer. This work is considered incidental to the Bituminous Pavement Reclamation pay item.
2. The road reclaimer shall be a self-propelled machine capable of effectively pulverizing the in- place bituminous pavement structure and blending a portion of the underlying aggregate base material to a depth of 12 inches in one pass. The machine shall have either an upward or downward rotational cutting hand and controls to maintain a constant cutting depth so as to produce a uniformly blended reclaimed mixture.
3. The existing pavement and base material shall be pulverized and blended to the specified width and a depth of 12 inches in one operation so that the entire mass of material is uniformly blended/mixed. Depending on the width of the reclaimer, it may take more than one pass horizontally to cover the entire width of the roadway.
4. The blended material shall meet the previous gradation requirements listed under Materials. In the event there are oversize particles in the existing base course (greater than 4 inches in size) the contractor shall either make additional passes with the reclaimer or remove and dispose of oversize particles as directed by the engineer. No additional compensation will be considered.
5. The Contractor shall take care to avoid disturbing or damaging any existing drainage or utility structures on the Project. The Contractor shall repair damage to any structure resulting from the pulverization operation at no expense to the Owner.
6. The contractor shall initially utilize a compactor that is self propelled and has a minimum weight of 25,000 pounds. The contractor shall additionally utilize either a vibratory steel drum roller capable of producing 250 lbs/in of drum width or a pneumatic tired roller (self propelled or towed) having a compacting width of 5 feet or more and sufficient mass to provide 100-250 lbs./in of rolling width.
7. The contractor shall compact the reclaimed layer to a minimum of 95 percent of ASTM D698. During the reclamation and compaction process, the contractor shall provide sufficient water so the reclaimed mixture will be at +/- 2 percent of the optimum moisture content per ASTM D698. If a nuclear density gauge is used to determine the in-situ density and moisture content, care should be taken to correct for the asphalt content of the reclaimed material. All reclaimed material shall be blended, spread, watered, compacted, and shaped, by the end of the workday.

8. Following reclamation and prior to paving, the contractor shall maintain the reclaimed surface so it is free of ruts, washboards, and potholes. This may require application of water and using a scarifying blade on a road grader. Reclaimed material with a "wash board" surface condition shall be scarified to a depth below that lowest surface of the wash boarded area and recompact immediately prior to paving. This work shall be performed at no additional cost to the Owner. Any costs associated with maintaining this surface is incidental to Bituminous Reclamation.
9. Prior to paving, water shall be applied **when directed by the engineer** for dust control.

F. Method of Measurement

1. Bituminous Reclamation will be measured and paid for on the basis of square yards reclaimed, graded and compacted. Payment will be by the square yard at the unit price shown on the Proposal for contract work.

G. Basis of Payment

1. Payment for Bituminous Reclamation at the Contract bid price will be compensation in full for all labor, equipment, and material costs required to perform the reclamation as specified, including the costs of traffic control, pulverizing, blending, spreading, watering, compacting, and shaping of the reclaimed bituminous pavement and aggregate material. Costs associated with the blading, shaping, and compacting of the reclaimed material to meet the required profile and cross-section is included in the Bituminous Reclamation bid price
2. No direct compensation will be made for water used in conjunction with the operations associated with pulverizing, blending, placing, compacting, shaping, and maintaining the reclaim material finished surface.
3. Payment is full compensation for all labor, tools, equipment, materials, and other incidentals necessary to complete the work in accordance with the specifications and as directed by the Engineer.

APPENDIX E: IMPORTANT INFORMATION

Important Information about your Geotechnical Report

IMPORTANT INFORMATION

ABOUT YOUR

GEOTECHNICAL ENGINEERING REPORT

More construction problems are caused by site subsurface conditions than any other factor. As troublesome as subsurface problems can be, their frequency and extent have been lessened considerably in recent years, due in large measure to programs and publications of ASFE/The Association of Engineering Firms Practicing in the Geosciences.

The following suggestions and observations are offered to help you reduce the Geotechnical-related delays, cost-overruns and other costly headaches that can occur during a construction project.

A GEOTECHNICAL ENGINEERING REPORT IS BASED ON A UNIQUE SET OF PROJECT-SPECIFIC FACTORS

A Geotechnical engineering report is based on a subsurface exploration plan designed to incorporate a unique set of project-specific factors. These typically include: the general nature of the structure involved, its size and configuration; the location of the structure on the site and its orientation; physical concomitants such as access roads, parking lots, and underground utilities, and the level of additional risk which the client assumed by virtue of limitations imposed upon the exploratory program. To help avoid costly problems, consult the geotechnical engineer to determine how any factors which change subsequent to the date of the report may affect its recommendations.

Unless your consulting Geotechnical engineer indicates otherwise, *your Geotechnical engineer report should not be used:*

- When the nature of the proposed structure is changed, for example, if an office building will be erected instead of a parking garage, or if a refrigerated warehouse will be built instead of an unrefrigerated one;
- when the size or configuration of the proposed structure is altered;
- when the location or orientation of the proposed structure is modified;
- when there is a change of ownership, or
- for application to an adjacent site.

Geotechnical engineers cannot accept responsibility for problems which may develop if they are not consulted after factors considered in their reports' development have changed.

MOST GEOTECHNICAL "FINDINGS" ARE PROFESSIONAL ESTIMATES

Site exploration identifies actual subsurface conditions only at those points where samples are taken, when they are taken.

Data derived through sampling and subsequent laboratory testing are extrapolated by Geotechnical engineers who then render an opinion about overall subsurface conditions, their likely reaction to proposed conditions, their likely reaction to proposed construction activity, and appropriate foundation design. Even under optimal circumstances actual conditions may differ from those inferred to exist, because no Geotechnical engineer, no matter how qualified, and not subsurface exploration program, no matter how comprehensive, can reveal what is hidden by earth, rock and time. The actual interface between materials may be far more gradual or abrupt than a report indicates. Actual conditions in areas not sampled may differ from predictions. *Nothing can be done to prevent the unanticipated, but steps can be taken to help minimize their impact.* For this reason, *most experienced owners retain their Geotechnical consultants through the construction stage, to identify variances, conduct additional tests which may be needed, and to recommend solutions to problems encountered on site.*

SUBSURFACE CONDITIONS CAN CHANGE

Subsurface conditions may be modified by constantly-changing natural forces. Because a Geotechnical engineering report is based on conditions which existed at the time of subsurface exploration, *construction decisions should not be based on a Geotechnical engineering report whose adequacy may have been affected by time.* Speak with the Geotechnical consultant to learn if additional tests are advisable before construction starts.

Construction operations at or adjacent to the site and natural events such as flood, earthquakes or groundwater fluctuations may also affect subsurface conditions and, thus, the continuing adequacy of a geotechnical report. The geotechnical engineer should be kept apprised of any such events, and should be consulted to determine if additional tests are necessary.

GEOTECHNICAL SERVICES ARE PERFORMED FOR SPECIFIC PURPOSES AND PERSONS

Geotechnical engineers' reports are prepared to meet the specific needs of specific individuals. A report prepared for a consulting civil engineer may not be adequate for a construction contractor, or even some other consulting civil engineer. Unless indicated otherwise, this report was prepared expressly for the client involved and expressly for purposes indicated by the client. Use by any other persons for any purpose, or by the client for a different purpose, may result in problems. *No individual other than the client should apply this report for its intended purpose without first conferring with the*

geotechnical engineer. No person should apply this report for any purpose other than that originally contemplated without first conferring with the geotechnical engineer.

A GEOTECHNICAL ENGINEERING REPORT IS SUBJECT TO MISINTERPRETATION

Costly problems can occur when other design professionals develop their plans based on misinterpretations of a geotechnical engineering report. To help avoid these problems, the geotechnical engineer should be retained to work with other appropriate design professionals to explain relevant geotechnical findings and to review the adequacy of their plans and specifications relative to geotechnical issues.

BORING LOGS SHOULD NOT BE SEPARATED FROM THE ENGINEERING REPORT

Final boring logs are developed by geotechnical engineers based upon their interpretation of field logs (assembled by site personnel) and laboratory evaluation of field samples. Only final boring logs customarily are included in geotechnical engineering reports. *These logs should not under any circumstances be redrawn* for inclusion in architectural or other design drawings, because drafters may commit errors or omissions in the transfer process. Although photographic reproduction eliminates this problem, it does nothing to minimize the possibility of contractors misinterpreting the logs during bid preparation. When this occurs, delays, disputes and unanticipated costs are the all-too-frequent result.

To minimize the likelihood of boring log misinterpretation, *give contractors ready access to the complete geotechnical engineering report* prepared or authorized for their use. Those

who do not provide such access may proceed under the *mistaken* impression that simply disclaiming responsibility for the accuracy of subsurface information always insulates them from attendant liability. Providing the best available information to contractors helps prevent costly construction problems and the adversarial attitudes which aggravate them to disproportionate scale.

READ RESPONSIBILITY CLAUSES CLOSELY

Because geotechnical engineering is based extensively on judgment and opinion, it is far less exact than other design disciplines. This situation has resulted in wholly unwarranted claims being lodged against geotechnical consultants. To help prevent this problem, geotechnical engineers have developed model clauses for use in written transmittals. These are *not* exculpatory clauses designed to foist geotechnical engineers' liabilities onto someone else. Rather, they are definitive clauses which identify where geotechnical engineers' responsibilities begin and end. Their use helps all parties involved recognize their individual responsibilities and take appropriate action. Some of these definitive clauses are likely to appear in your geotechnical engineering report, and you are encouraged to read them closely. your geotechnical engineer will be pleased to give full and frank answers to your questions.

OTHER STEPS YOU CAN TAKE TO REDUCE RISK

Your consulting geotechnical engineer will be pleased to discuss other techniques which can be employed to mitigate risk. In addition, ASFE as developed a variety of materials which may be beneficial. Contact ASFE for a complimentary copy of its publications directory.

Published by

The logo for ASFE (The Association of Engineering Firms Practicing in the Geosciences) features the letters 'ASFE' in a large, bold, blue, sans-serif font. The letters are set against a light beige background that has a rounded right edge.

THE ASSOCIATION
OF ENGINEERING FIRMS
PRACTICING IN THE
GEOSCIENCES

8811 Colesville Road/Suite G106/Silver Spring, Maryland 20910/(301)565-2733